

VFI series - Stainless steel worm gearboxes

Riduttori a vite senza fine completamente in acciaio inox

Section **2**
Sezione 2



FEATURES

Caratteristiche

Stainless steel worm gearboxes

Riduttori a vite senza fine completamente in acciaio inox

Type <i>Tipo</i>	Torque <i>Coppia</i>	Center distance <i>Interasse</i>	Input power <i>Potenza in entrata</i>	Hollow output shaft <i>Albero cavo in uscita</i>
I30	21 Nm	30 mm	0.09 ÷ 0.18 kW	ø14 mm
I45	41 Nm	45 mm	0.12 ÷ 0.37 kW	ø18 mm ø19 mm
I50	72 Nm	50 mm	0.12 ÷ 0.75 kW	ø25 mm ø24 mm
I63	147 Nm	63 mm	0.37 ÷ 1.8 kW	ø25 mm ø28 mm
I85	347 Nm	85 mm	0.55 ÷ 4.0 kW	ø35 mm
I11	651 Nm	110 mm	1.1 ÷ 4.0 kW	ø42 mm



This product is:

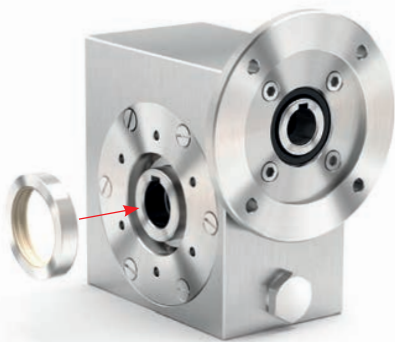

Twin viton seals with stainless steel shield.

Anelli di tenuta in viton con schermo protettivo in acciaio inox.

Mounting holes on both sides of the housing for versatile mounting.

Fori di montaggio in entrambi i lati della cassa.

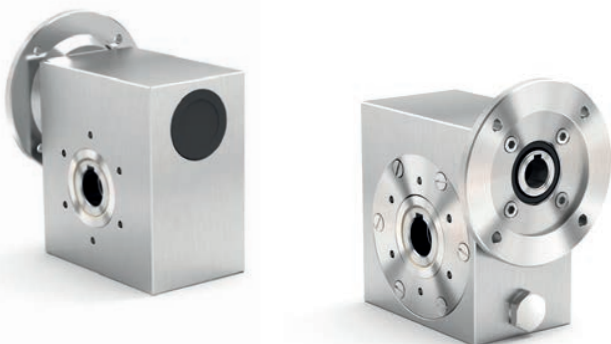

FEATURES

Caratteristiche



**Output shaft is produced in AISI 316L.
Special cover assures full protection of oil seals.**

Mozzo e albero in uscita in AISI 316L e coperchietto protettivo per anelli paraolio.

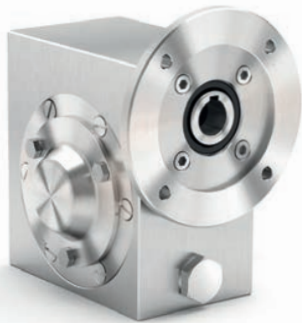

O-ring closure is used for a new oil seals cover.

Nuovo coperchietto protettivo per anelli paraolio chiuso con o-ring.



Removable hollow shaft with key for safe torque transmissions.

Albero cavo removibile con chiavetta mozzo/corona.











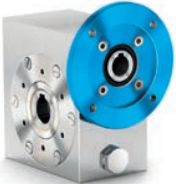
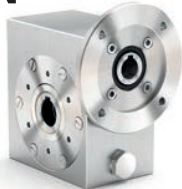

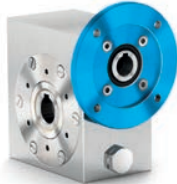







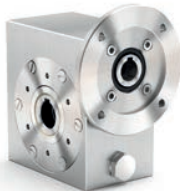
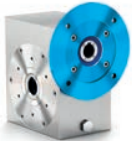



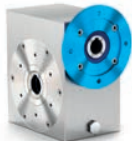

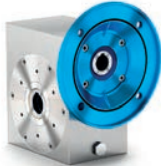
Special high tech housing finishing.

Finitura speciale sulla cassa.

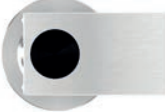
How to order

Codifica

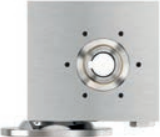
P	I50	UN	10	I
Type <i>Tipo</i>	Size <i>Grandezza</i>	Mounting <i>Montaggio</i>	Ratio <i>Rapporto</i>	Hub <i>Mozzo corona</i>
P 	I30 I45 I50 I63 I85 I11	UN 	 See technical data table <i>Vedi tabelle dati tecnici</i>	I  Standard I30 -> ø14 I45 -> ø18 I50 -> ø25 I63 -> ø25 I85 -> ø35 I11 -> ø42
M 		FL 		X Special series I45 -> ø19 I50 -> ø24
B 		BR 		Z Inch I45 -> ø0.750" I50 -> ø1.000" I63 -> ø1.250" I85 -> ø1.500" I11 -> ø2.000"
R 				

S	-Q	B	B3	-
Output shaft <i>Albero lento</i>	Motor size <i>Grandezza motore</i>	Terminal box position <i>Posizione morsetti</i>	Mounting position <i>Posizione di montaggio</i>	Coupling <i>Giunto</i>
Ø 	IEC B5  -D -> 80B5 (ø200) -E -> 90B5 (ø200)	A 	B3 	- No indication Standard bore <i>Nessuna indicazione</i> Foro standard
S 	IEC B14  -O -> 56B14 (ø80) -P -> 63B14 (ø90) -Q -> 71 B14 (ø105) -R -> 80 B14 (ø120) -T -> 90 B14 (ø140) -U -> 100-112B14 (ø160)	B 	B8 	P Input bore reduced one size <i>Foro entrata ridotto di una entrata</i>
	NEMA  -W -> 56C (ø6.5") -X -> 143/5TC (ø6.5") -Y -> 182/4TC (ø8.88") AA -> 213/5TC (ø8.88")	C 	B6 	Q Input bore reduced two sizes <i>Foro entrata ridotto di due misure</i>
	-M 	D 	B7 	 A -> 9mm B -> 11mm C -> 14mm D -> 19mm E -> 24mm F -> 28mm
-0 			V5 	
			V6 	0 Without coupling <i>Senza giunto</i> 

Useful formulas

Formule utili

Required power - Potenza richiesta

Lifting - Sollevamento

$$P_{[kW]} = \frac{M_{[Kg]} \cdot g_{[9.81]} \cdot v_{[m/s]}}{1000}$$

Rotation - Rotazione

$$P_{[kW]} = \frac{M_{[Nm]} \cdot n_{[rpm]}}{9550}$$

Linear movement - Traslazione

$$P_{[kW]} = \frac{F_{[N]} \cdot v_{[m/s]}}{1000}$$

Torque - Coppia

$$M_{[Nm]} = \frac{9550 \cdot P_{[kW]}}{n_{[rpm]}}$$

$$M_{[lb\ in]} = \frac{63030 \cdot P_{[HP]}}{n_{[rpm]}}$$

Radial loads - Carichi radiali

Radial load generated by external transmissions keyed onto input and/or output shafts.

Forza radiale generata da organi di trasmissione calettati sugli alberi di ingresso e/o uscita.

$$F_{R[N]} = \frac{M_{[Nm]} \cdot 2000}{d_{[mm]}} \cdot f_k$$

$$F_{R[N]} = \frac{M_{[lb\ in]} \cdot 8.9}{d_{[in]}} \cdot f_k$$

M: Output torque - Momento torcente

d: Diam. of driving element - Diametro primitivo

f_k: Factor - Coefficiente di trasformazione

1.15: Gearwheels - Ingranaggi

1.25: Chain sprockets - Catena

1.75: Narrow v-belt pulley - Cinghia Trapezoidale

2.50: Flat-belt pulley - Cinghia piatta

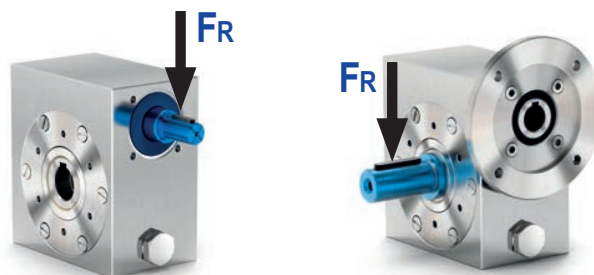

If your application requires higher radial loads, contact our technical office. Higher loads may be possible.

Nel caso la vostra applicazione richieda carichi radiali superiori consultare il nostro ufficio tecnico, valori maggiori possono essere accettati.

How to select a gearbox

Come selezionare un riduttore

- A** Select required torque (according to service factor)
Seleziona la coppia desiderata (comprensiva del fattore di servizio)
- B** Select output speed
Seleziona la velocità in uscita
- C** Select gear ratio in the line corresponding to the chosen motor power
Sulla riga corrispondente alla motorizzazione prescelta si può rilevare il rapporto di riduzione
- D** Select motor flange available (if requested)
Scegli la flangia disponibile (se richiesta)

Gear size <i>Grandezza riduttore</i>	C	Ratio <i>Rapporto</i>	Transmitted torque <i>Momento torcente trasmesso</i>	Nominal power <i>Potenza nominale</i>	Flange code <i>Codice flangia</i>	Dynamic efficiency <i>Rendimento dinamico</i>	Input speed <i>Velocità in entrata</i>
---	----------	--------------------------	---	--	--------------------------------------	--	---

130

21 Nm

Stainless steel worm gearboxes

Riduttori a vite senza fine completamente in acciaio inox

Input speed (n ₁) = 1400 min ⁻¹													
Output speed	Ratio	Motor power	Output torque	Service factor	Nominal power	Nominal torque	B5 motor flanges		B14 motor flanges		Dynamic efficiency	Tooth module	Ratios code
n ₂ [min ⁻¹]	i	P _{1M} [kW]	M _{2M} [Nm]	f.s	P _{1R} [kW]	M _{2R} [Nm]	-	-	-O	-P	RD	[mm]	
280	5	0.18	5	3.3	0.60	17	-	-	56	63	82	1.26	01
200	7	0.18	7	2.4	0.44	17	-	-	B-C	B-C	80	1.44	02
140	10	0.18	10	1.8	0.32	17	-	-	B-C	B-C	78	1.44	03
93	15	0.18	13	1.4	0.25	19	-	-	B-C	B-C	73	1.44	04
70	20	0.18	17	1.1	0.20	19	-	-	B-C	B-C	70	1.09	05
47	30	0.12	15	1.4	0.17	21	-	-	B-C	B-C	62	1.44	06
35	40	0.12	19	1.1	0.13	20	-	-	B-C	B-C	57	1.09	07
23	61	0.09	19	1.1	0.10	20	-	-	B-C	B-C	50	0.72	08
17.5	80	0.09	16	1.0	0.06	16	-	-	B-C	B-C	48	0.56	09

- B** Output speed
Velocità in uscita
- Motor power
Potenza motore
- Service factor
Fattore di servizio
- A** Nominal torque
Momento torcente nominale
- Nominal module
Modulo nominale
- Notes
Note

Type of load and starts per hour <i>Tipo di carico e avviamenti per ora</i>	Oper. hours per day <i>Ore di funz. giorn.</i>	Oper. hours per day		
		<2h	2÷8h	8÷16h
Continuous or intermittent application with start / hour <i>Applicazione continua o intermittente con numero operazioni/ora</i>	Uniform - <i>Uniforme</i>	0.9	1	1.25
	Moderate - <i>Moderato</i>	1	1.25	1.5
	Heavy - <i>Forte</i>	1.25	1.5	1.75
Intermittent application with start / hour <i>Applicazione intermittente con numero operazioni/ora</i>	Uniform - <i>Uniforme</i>	1.25	1.5	1.75
	Moderate - <i>Moderato</i>	1.5	1.75	2
	Heavy - <i>Forte</i>	1.75	2	2.25

- D** Motor flange available
Flange disponibili
- B)** Mounting with reduction bushing
Montaggio con boccia di riduzione
- C)** Motor flange holes position/terminal box position
Posizione fori flangia/basetta motore
- B)** Available without reduction bushing
Disponibile anche senza boccia

I30

21
Nm

Stainless steel worm gearboxes

Riduttori a vite senza fine completamente in acciaio inox

Input speed (n_1) = 1400 min⁻¹

Output speed n_2 [min ⁻¹]	Ratio i	Motor power P_{1M} [kW]	Output torque M_{2M} [Nm]	Service factor f.s	Nominal power P_{1R} [kW]	Nominal torque M_{2R} [Nm]	B5 motor flanges		B14 motor flanges		Dynamic efficiency RD	Tooth module [mm]	Ratios code
							-	-	-O	-P			
280	5	0.18	5	3.3	0.60	17							
200	7	0.18	7	2.4	0.44	17			B-C		82	1.26	01
140	10	0.18	10	1.8	0.32	17			B-C		80	1.44	02
93	15	0.18	13	1.4	0.25	19			B-C		78	1.44	03
70	20	0.18	17	1.1	0.20	19			B-C		73	1.44	04
47	30	0.12	15	1.4	0.17	21			B-C		70	1.09	05
35	40	0.12	19	1.1	0.13	20			B-C		62	1.44	06
23	61	0.09	19	1.1	0.10	20			B-C		57	1.09	07
17.5	80	0.09	16	1.0	0.06	16			B-C		50	0.72	08
									B-C		48	0.56	09

* The nominal power should be reduced if the ambient temperature is $\geq 30^\circ\text{C}$, or when a cooler gearbox is required.

* Diminuire la potenza nominale in caso di temperatura ambiente $\geq 30^\circ\text{C}$ o se è richiesta una bassa temperatura di utilizzo del riduttore.

Motor flanges available
Flange motore disponibili



B) Supplied with reduction bushing
Fornito con bussola di riduzione



B) Available on request without reduction bushing
Disponibile a richiesta senza bussola di riduzione



C) Motor flange holes position
Posizione fori flangia motore

Lubrication

Lubrificazione

Unit I30 is supplied with synthetic oil to assure long life lubrication.

Food grade oil is available on request.

See Table 1 for lubrication and recommended quantity.

See Table 2 for possible radial and axial loads on the gearbox.

Il riduttore tipo I30 viene fornito con olio sintetico e lubrificazione tipo "long life".

Disponibile a richiesta olio alimentare.

Vedi Tabella 1 per oli e quantità consigliati.

Vedi Tabella 2 per i carichi radiali e assiali applicabili al riduttore.

Oil quantity for
all positions:
0.06Lt.

Quantità olio per tutte
le posizioni: 0.06Lt

Agip
Telium VSF 320

Shell
Omala S4 WE 320

* For more details on lubrication and plugs check our website. **Tab. 1**
* Per maggiori dettagli su lubrificazione e tappi olio vedi il nostro sito web.

Radial and axial loads

Carichi radiali e assiali

Output shaft

Albero di uscita

n_2 [min ⁻¹]	F_A [N]	F_R [N]
200	120	600
150	140	700
100	160	800
75	180	900
50	200	1000
25	250	1250
15	280	1400

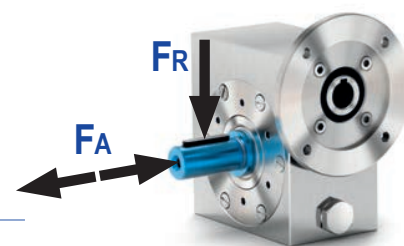

Input shaft

Albero in entrata

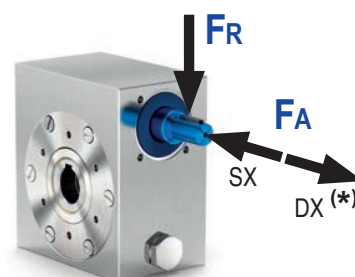

n_1 [min ⁻¹]	F_A [N]	F_R [N]
1400	20	100

* Strong axial loads in the DX direction are not allowed.

* Non sono consentiti forti carichi assiali con direzione DX

Tab. 2

21 Nm

I30

PI30UN...

Basic gearbox
Riduttore base

Gearbox weight
peso riduttore **2.5 kg**

M. flanges	Kit code	øF	A
56B14	KI304046	80	61.5
63B14	KI304045	90	62.5

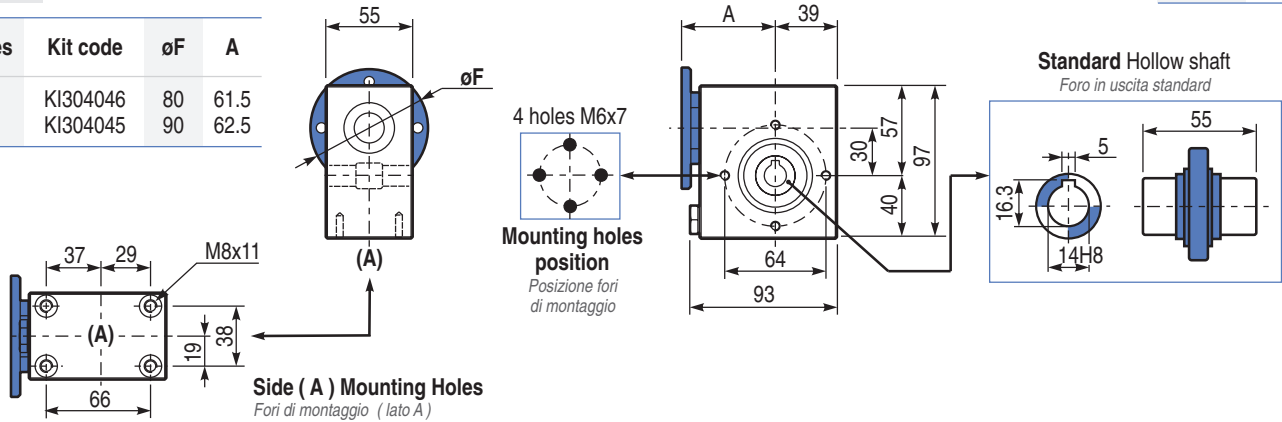

B_I30UN...

Modular base
Base modulare

PI30FL...

Output flange
Flangia uscita

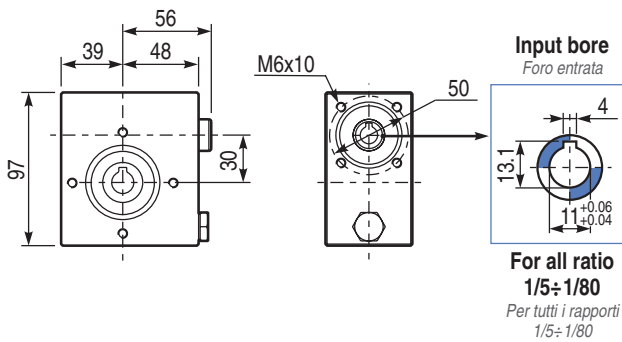

kit cod. KI459011

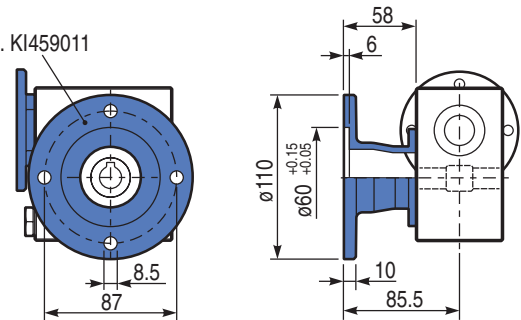

R_I30UN...

Input shaft
Albero in entrata

PI30BR...

Reaction arm
Braccio di reazione

PI30.....S...

Single Shaft
Albero lento semplice

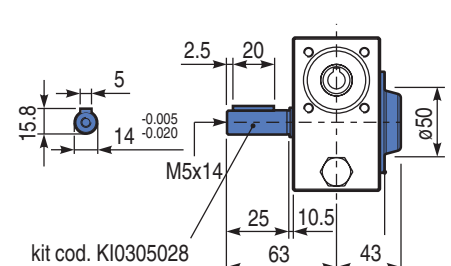
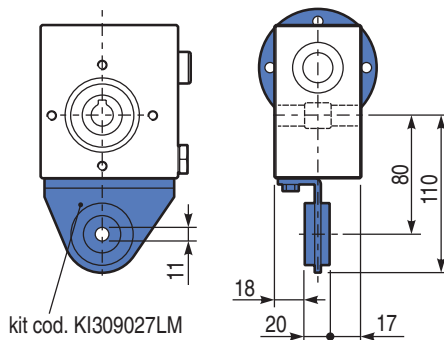
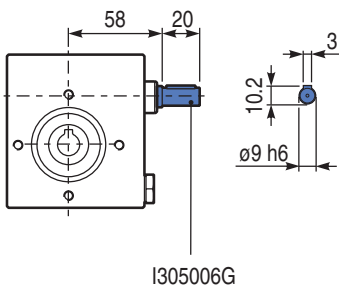

kit cod. KI450211
Protection cup
(on request)
A richiesta coperchio di protezione



145

41 Nm

Stainless steel worm gearboxes

Riduttori a vite senza fine completamente in acciaio inox

Input speed (n_1) = 1400 min⁻¹

Output speed n_2 [min ⁻¹]	Ratio i	Motor power P_{1M} [kW]	Output torque M_{2M} [Nm]	Service factor f.s	Nominal power P_{1R} [kW]	Nominal torque M_{2R} [Nm]	B5 motor flanges		B14 motor flanges		Dynamic efficiency RD	Tooth module  [mm]	Ratios code 
							-	-	-P 63	-Q 71			
200	7	0.37	14	2.2	0.80	30			B-C	80	2.2	01	
140	10	0.37	20	1.5	0.57	30			B-C	79	2.2	02	
100	14	0.37	27	1.1	0.41	30			B-C	77	2.4	03	
67	21	0.37	36	1.2	0.43	41			B-C	67	1.6	04	
50	28	0.25	31	1.3	0.33	41			B-C	65	2.5	05	
38	37	0.25	40	1.0	0.26	41			B-C	63	1.8	06	
30	46	0.25	46	0.9	0.22	41			B-C	59	1.5	07	
23	60	0.18	41	1.0	0.18	41			B-C	56	1.2	08	
20	70	0.12	31	1.0	0.12	30			B-C	54	1.0	09	
13.7	102	0.12	41	0.7	0.09	29			B-C	49	0.72	10	

* The nominal power should be reduced if the ambient temperature is $\geq 30^\circ\text{C}$, or when a cooler gearbox is required.

* Diminuire la potenza nominale in caso di temperatura ambiente $\geq 30^\circ\text{C}$ o se è richiesta una bassa temperatura di utilizzo del riduttore.

-  Motor flanges available
Flange motore disponibili
-  B) Supplied with reduction bushing
Fornito con bussola di riduzione
-  B) Available on request without reduction bushing
Disponibile a richiesta senza bussola di riduzione
-  C) Motor flange holes position
Posizione fori flangia motore

Lubrication

Lubrificazione

Unit I45 is supplied with synthetic oil to assure long life lubrication. Food grade oil is available on request.

See Table 1 for lubrication and recommended quantity.

See Table 2 for possible radial and axial loads on the gearbox.

Il riduttore tipo I45 viene fornito con olio sintetico e lubrificazione tipo "long life".

Disponibile a richiesta olio alimentare.

Vedi Tabella 1 per oli e quantità consigliati.

Vedi Tabella 2 per i carichi radiali e assiali applicabili al riduttore.

Agip Telium VSF 320
Shell Omala S4 WE 320

B3
Standard
0.15 LT

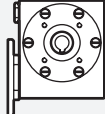
B8
On request
0.15 LT

B6
On request
0.15 LT

V5
On request
0.15 LT

B7
On request
0.20 LT

V6
On request
0.15 LT

For more details on lubrication and plugs check our website.

Per maggiori dettagli su lubrificazione e tappi olio vedi il nostro sito web.

Tab. 1

Radial and axial loads

Carichi radiali e assiali

Output shaft

Albero di uscita

n_2 [min ⁻¹]	F_A [N]	F_R [N]
200	180	900
150	200	1000
100	220	1100
75	240	1200
50	260	1400
25	300	1800
15	400	2000

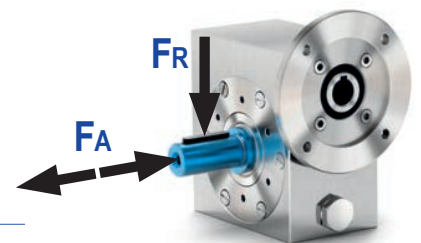

Input shaft

Albero in entrata

n_1 [min ⁻¹]	F_A [N]	F_R [N]
1400	42	210

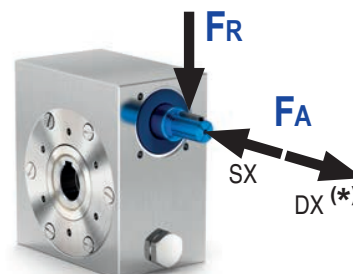

* Strong axial loads in the DX direction are not allowed.

* Non sono consentiti forti carichi assiali con direzione DX

Tab. 2

41 Nm

145

PI45UN... Basic gearbox
Riduttore base

Gearbox weight
peso riduttore 5.0 kg

M. flanges	Kit code	øF	A
63B14	KI504047	90	73.5
71B14	KI504045	105	71

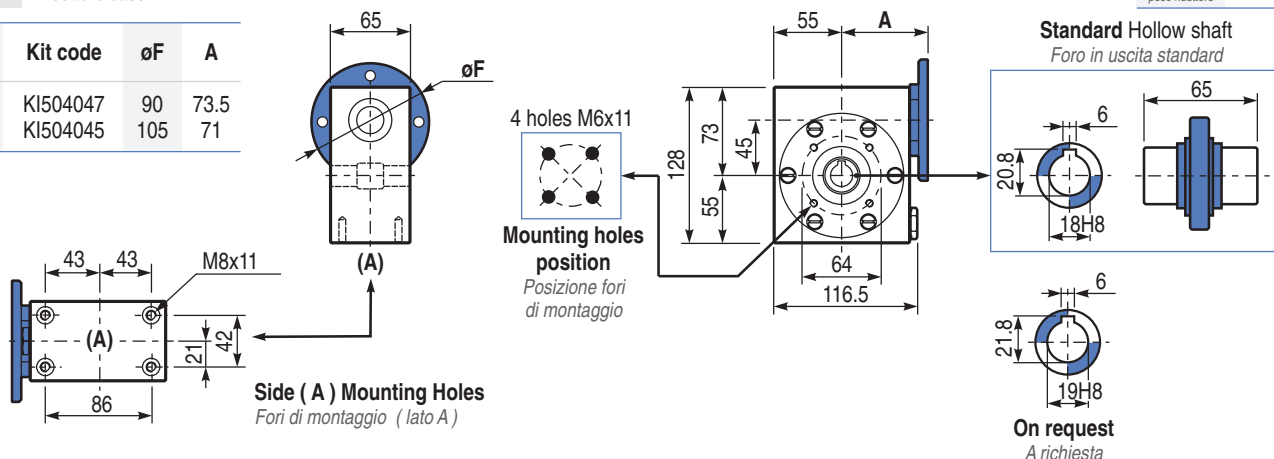

B145UN... Modular base
Base modulare

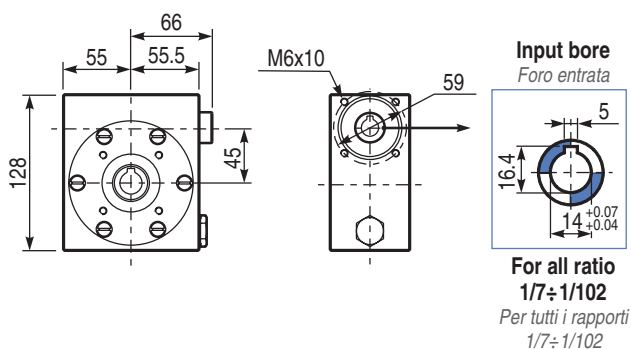

PI45FL... Output flange
Flangia uscita

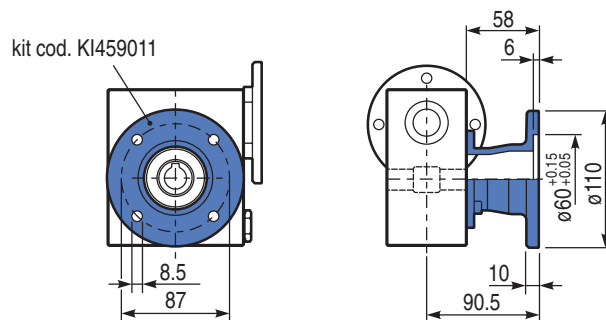

RI45UN... Input shaft
Albero in entrata

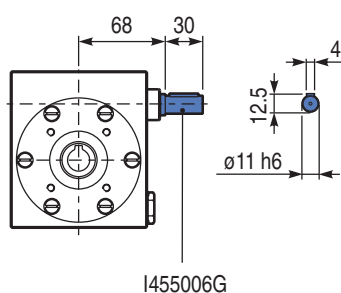

PI45BR... Reaction arm
Braccio di reazione

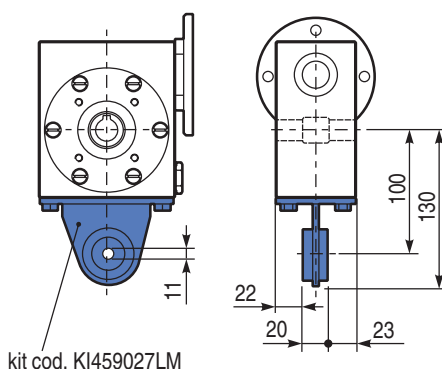

PI45...S... Single Shaft
Albero lento semplice

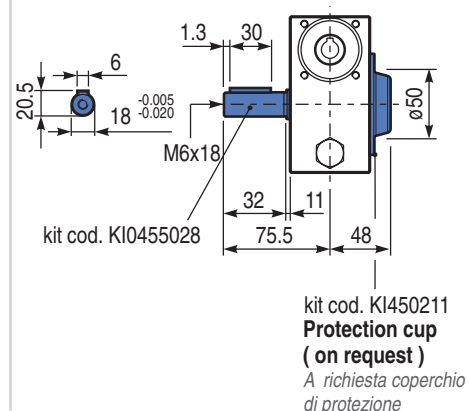



150

72 Nm

Stainless steel worm gearboxes

Riduttori a vite senza fine completamente in acciaio inox

Input speed (n_1) = 1400 min⁻¹

Output speed n_2 [min ⁻¹]	Ratio i	Motor power P_{1M} [kW]	Output torque M_{2M} [Nm]	Service factor $f.s$	Nominal power P_{1R} [kW]	Nominal torque M_{2R} [Nm]	Motor flanges			Dynamic efficiency RD	Tooth module  [mm]	Ratios code 		
							B5 motor flanges	B14 motor flanges						
							-	-	-P 63	-Q 71	-R 80			
200	7	0.75	29	1.9	1.5	57			B-C	B		82	2.5	01
140	10	0.75	41	1.5	1.1	62			B-C	B		80	2.4	02
100	14	0.75	57	1.2	0.90	68			B-C	B		79	2.6	03
78	18	0.55	51	1.2	0.67	62			B-C	B		75	2.0	04
54	26	0.55	67	1.0	0.54	66			B-C	B		69	2.7	05
47	30	0.55	79	0.9	0.50	72			B-C	B		70	2.5	12
39	36	0.37	63	1.2	0.43	72			B-C			69	2.1	06
33	43	0.37	72	1.0	0.35	68			B-C			66	1.8	07
28	50	0.25	53	1.2	0.31	66			B-C			62	1.5	13
23	60	0.25	59	1.0	0.26	62			B-C			58	1.3	08
21	68	0.25	66	0.9	0.22	58			B-C			57	1.2	09
17.5	80	0.18	53	1.1	0.19	57			B-C			54	1.0	10
14	100	0.12	41	1.3	0.15	51			B-C			50	0.8	11

* The nominal power should be reduced if the ambient temperature is $\geq 30^\circ\text{C}$, or when a cooler gearbox is required.

* Diminuire la potenza nominale in caso di temperatura ambiente $\geq 30^\circ\text{C}$ o se è richiesta una bassa temperatura di utilizzo del riduttore.

-  **Motor flanges available**
Flange motore disponibili
-  **B) Supplied with reduction bushing**
Fornito con bussola di riduzione
- B) Available on request without reduction bushing**
Disponibile a richiesta senza bussola di riduzione
-  **C) Motor flange holes position**
Posizione fori flangia motore

Lubrication

Lubrificazione

Unit 150 is supplied with synthetic oil to assure long life lubrication. Food grade oil is available on request.

See Table 1 for lubrication and recommended quantity.

See Table 2 for possible radial and axial loads on the gearbox.

Il riduttore tipo 150 viene fornito con olio sintetico e lubrificazione tipo "long life".

Disponibile a richiesta olio alimentare.

Vedi Tabella 1 per oli e quantità consigliati.

Vedi Tabella 2 per i carichi radiali e assiali applicabili al riduttore.

Agip **Shell**
Telium VSF 320 Omala S4 WE 320

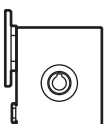
B3
Standard
0.22 LT 

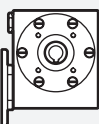
B8
On request
0.22 LT 

B6
On request
0.22 LT 

V5
On request
0.22 LT 

B7
On request
0.28 LT 

V6
On request
0.22 LT 

For more details on lubrication and plugs check our website.

Per maggiori dettagli su lubrificazione e tappi olio vedi il nostro sito web.

Radial and axial loads

Carichi radiali e assiali

Output shaft

Albero di uscita

n_2 [min ⁻¹]	F_A [N]	F_R [N]
200	240	1200
150	280	1400
100	300	1500
75	340	1700
50	380	1900
25	480	2500
15	560	2800

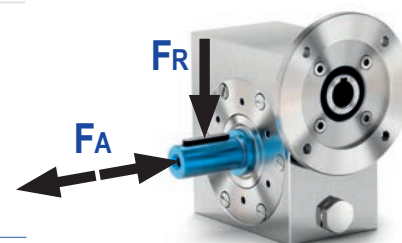

Input shaft

Albero in entrata

n_1 [min ⁻¹]	F_A [N]	F_R [N]
1400	76	380

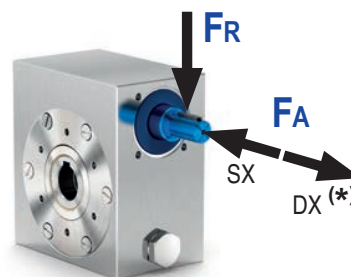

* Strong axial loads in the DX direction are not allowed.

* Non sono consentiti forti carichi assiali con direzione DX

72
Nm

150

PI50UN... **Basic gearbox**
Riduttore base

Gearbox weight 7.3 kg
peso riduttore

M. flanges	Kit code	øF	A
63B14	KI504047	90	78
71B14	KI504045	105	78
80B14	KI504046	120	

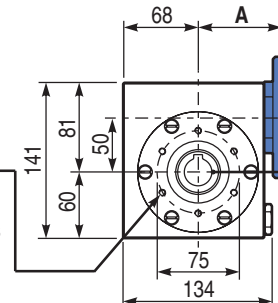
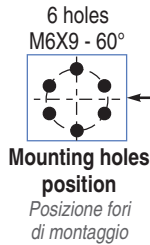
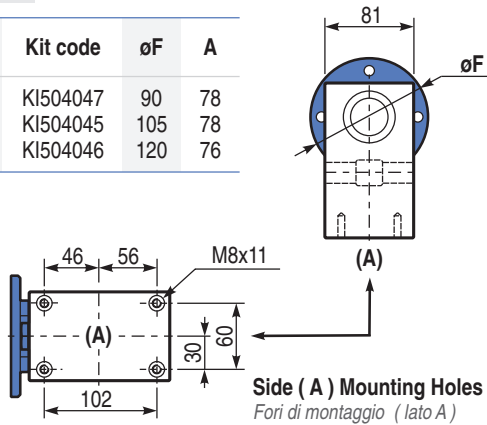

Standard Hollow shaft
Foro in uscita standard

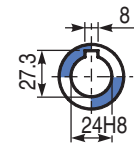
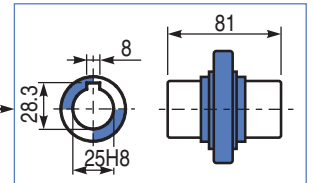

On request
A richiesta

B150UN... **Modular base**
Base modulare

Input bore
Foro entrata

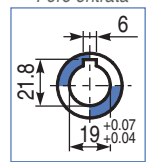
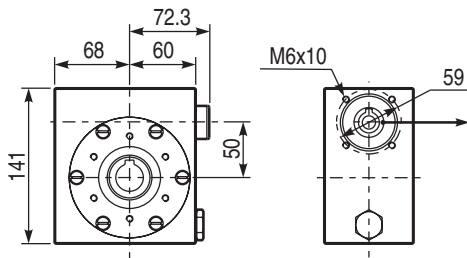

From 1/7 to 1/30
Dal 1/7 al 1/30

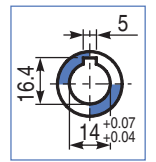

From 1/36 to 1/100
Dal 1/36 al 1/100

PI50FL... **Output flange**
Flangia uscita

kit cod. KI509011

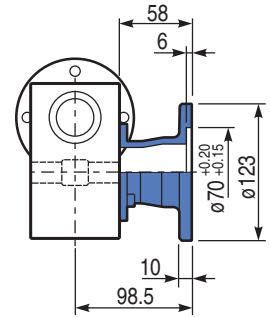
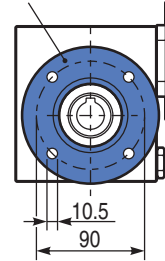

R150UN... **Input shaft**
Albero in entrata

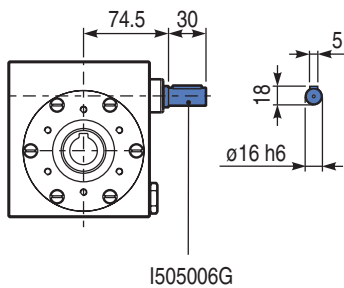

1505006G

PI50BR... **Reaction arm**
Braccio di reazione

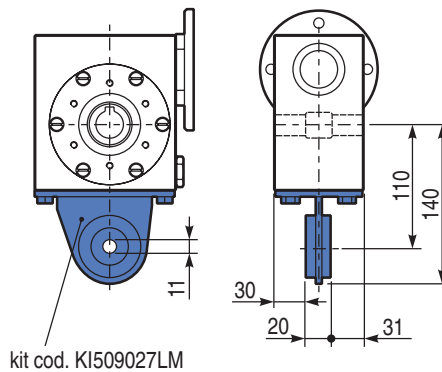

kit cod. KI509027LM

PI50.....S... **Single Shaft**
Albero lento semplice

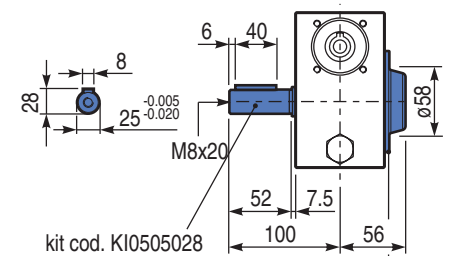

kit cod. KI0505028

kit cod. KI500211
Protection cup
(on request)
A richiesta coperchio di protezione



I63

147 Nm

Stainless steel worm gearboxes



Riduttori a vite senza fine completamente in acciaio inox

Input speed (n_1) = 1400 min⁻¹

Output speed n_2 [min ⁻¹]	Ratio i	Motor power P_{1M} [kW]	Output torque M_{2M} [Nm]	Service factor $f.s$	Nominal power P_{1R} [kW]	Nominal torque M_{2R} [Nm]	B5 motor flanges			B14 motor flanges			Dynamic efficiency RD	Tooth module  [mm]	Ratios code 
							-	-	-	-Q	-R	-T			
200	7	1.8	71	1.8	3.2	125				B-C	B-C		83	3.1	01
140	10	1.8	99	1.4	2.4	134				B-C	B-C		81	3.1	02
93	15	1.5	121	1.1	1.7	138				B-C	B-C		79	3.1	03
74	19	1.1	111	1.2	1.4	138				B-C	B-C		78	2.6	04
58	24	1.1	135	1.0	1.2	142				B-C	B-C		75	2.0	05
47	30	1.1	167	0.9	0.96	146				B-C	B-C		74	3.2	06
39	36	0.75	125	1.2	0.88	147				B-C	B-C		68	2.7	07
35	40	0.75	135	1.0	0.78	140				B-C	B-C		66	2.5	13
31	45	0.55	111	1.2	0.67	135				B-C	C		66	2.1	08
23	60	0.55	140	0.9	0.51	130				B-C	C		62	1.6	12
21	67	0.55	151	0.8	0.45	124				B-C	C		60	1.5	09
17.5	80	0.37	115	1.0	0.38	119				B-C	C		57	1.3	10
14.9	94	0.37	123	1.0	0.36	119				B-C	C		52	1.1	11

* The nominal power should be reduced if the ambient temperature is $\geq 30^\circ\text{C}$, or when a cooler gearbox is required.

* Diminuire la potenza nominale in caso di temperatura ambiente $\geq 30^\circ\text{C}$ o se è richiesta una bassa temperatura di utilizzo del riduttore.

-  **Motor flanges available**
Flange motore disponibili
-  **B) Supplied with reduction bushing**
Fornito con bussola di riduzione
- B) Available on request without reduction bushing**
Disponibile a richiesta senza bussola di riduzione
-  **C) Motor flange holes position**
Posizione fori flangia motore

Lubrication

Lubrificazione

Unit I63 is supplied with synthetic oil to assure long life lubrication. Food grade oil is available on request.

See Table 1 for lubrication and recommended quantity.

See Table 2 for possible radial and axial loads on the gearbox.

Il riduttore tipo I63 viene fornito con olio sintetico e lubrificazione tipo "long life".

Disponibile a richiesta olio alimentare.

Vedi Tabella 1 per oli e quantità consigliati.

Vedi Tabella 2 per i carichi radiali e assiali applicabili al riduttore.

Agip Shell
Teliuim VSF 320 Omala S4 WE 320

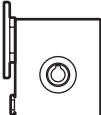
B3
Standard
0.60 LT 

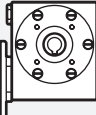
B8
On request
0.60 LT 

B6
On request
0.60 LT 

V5
On request
0.60 LT 

B7
On request
0.82 LT 

V6
On request
0.60 LT 

For more details on lubrication and plugs check our website.

Per maggiori dettagli su lubrificazione e tappi olio vedi il nostro sito web.

Radial and axial loads

Carichi radiali e assiali

Output shaft

Albero di uscita

n_2 [min ⁻¹]	F_A [N]	F_R [N]
200	360	1800
150	400	2000
100	460	2300
75	500	2500
50	600	3000
25	700	3800
15	800	4000

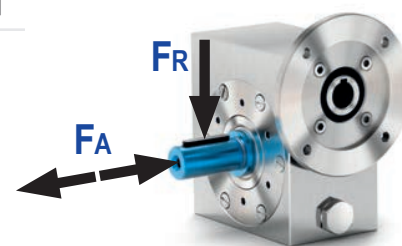

Input shaft

Albero in entrata

n_1 [min ⁻¹]	F_A [N]	F_R [N]
1400	90	450

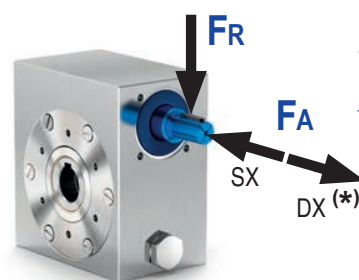

* Strong axial loads in the DX direction are not allowed.

* Non sono consentiti forti carichi assiali con direzione DX

147 Nm

163

PI63UN... **Basic gearbox**
Riduttore base

Gearbox weight
peso riduttore **14.6 kg**

M. flanges	Kit code	øF	A
71B14	KI634047	105	97
80B14	KI634046	120	98
90B14	KI634041	140	

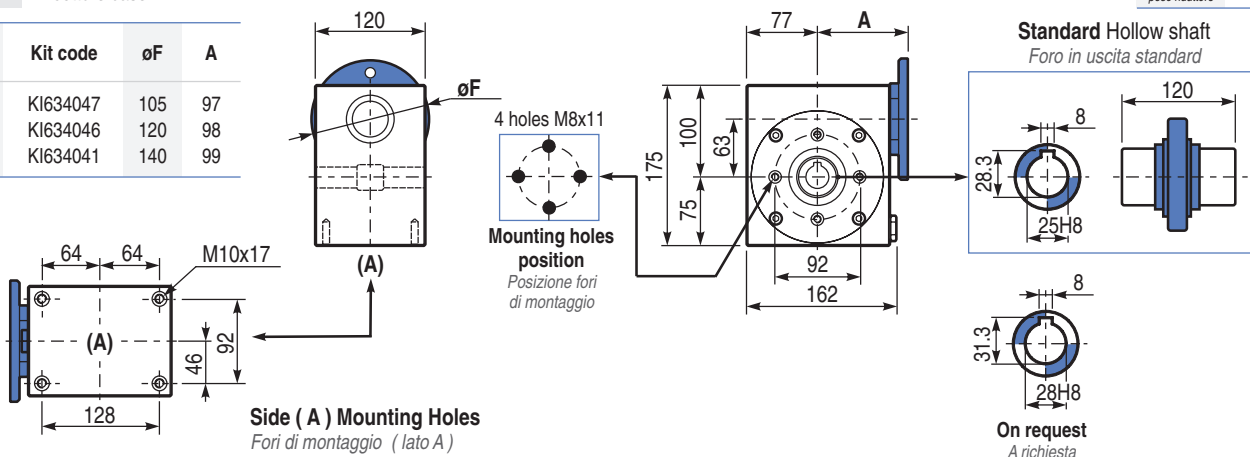

BI63UN... **Modular base**
Base modulare

Input bore
Foro entrata

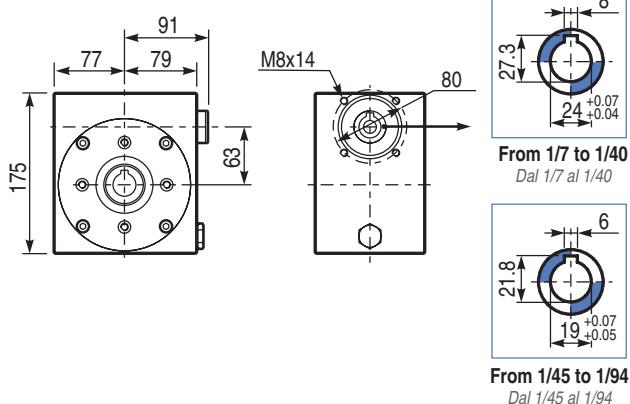

PI63FL... **Output flange**
Flangia uscita

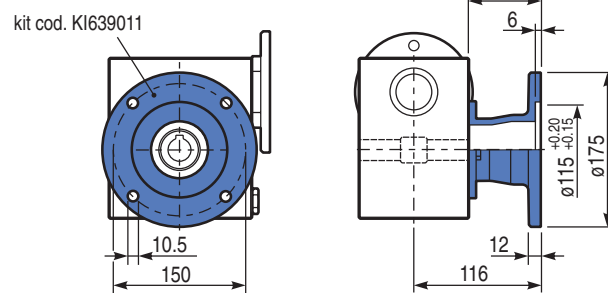

RI63UN... **Input shaft**
Albero in entrata

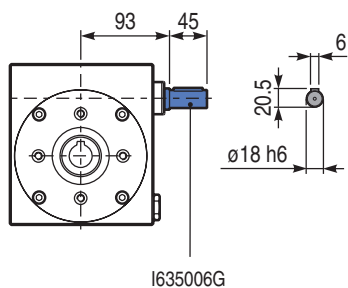

PI63BR... **Reaction arm**
Braccio di reazione

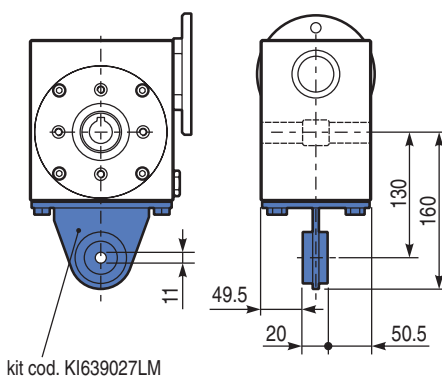

PI63...S... **Single Shaft**
Albero lento semplice

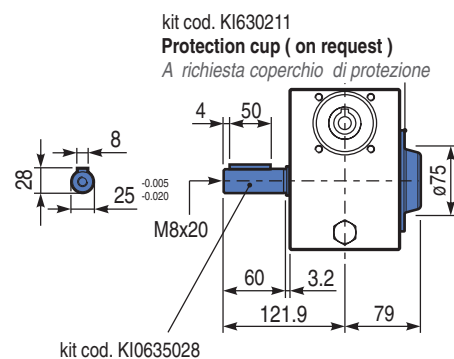



185

347 Nm

Stainless steel worm gearboxes

Riduttori a vite senza fine completamente in acciaio inox

Input speed (n_1) = 1400 min⁻¹

Output speed n_2 [min ⁻¹]	Ratio i	Motor power P_{1M} [kW]	Output torque M_{2M} [Nm]	Service factor $f.s$	Nominal power P_{1R} [kW]	Nominal torque M_{2R} [Nm]	B5 motor flanges		B14 motor flanges	Dynamic efficiency RD	Tooth module  [mm]	Ratios code 
							-D	-E	-U			
200	7	4.0	168	1.5	6.1	257	B	B	100 - 112	88	4.23	01
140	10	4.0	218	1.3	5.2	284	B	B		80	4.2	02
100	14	3.0	223	1.4	4.1	305	B	B		78	4.5	03
70	20	2.2	237	1.2	2.7	294	B	B		79	3.4	04
64	22	2.2	258	1.1	2.5	294	B	B		78	3.1	05
50	28	2.2	315	1.1	2.4	347	B	B		75	4.7	06
37	38	1.5	276	1.2	1.8	336	B			71	3.5	07
30	46	1.5	320	1.0	1.5	326	B			68	3.1	08
27	52	1.1	258	1.1	1.2	289	B			66	2.7	09
21	67	1.1	327	0.9	0.97	289	B			65	2.1	10
18.9	74	0.75	220	1.2	0.91	268	B			58	1.9	11
14.6	96	0.55	191	1.3	0.70	242	B			53	1.5	12

* The nominal power should be reduced if the ambient temperature is $\geq 30^\circ\text{C}$, or when a cooler gearbox is required.

* Diminuire la potenza nominale in caso di temperatura ambiente $\geq 30^\circ\text{C}$ o se è richiesta una bassa temperatura di utilizzo del riduttore.

-  Motor flanges available
Flange motore disponibili
-  B) Supplied with reduction bushing
Fornito con bussola di riduzione
-  C) Motor flange holes position
Posizione fori flangia motore

Lubrication

Lubrificazione

Unit 185 is supplied with synthetic oil to assure long life lubrication.

Food grade oil is available on request.

See Table 1 for lubrication and recommended quantity.

See Table 2 for possible radial and axial loads on the gearbox.

Il riduttore tipo 185 viene fornito con olio sintetico e lubrificazione tipo "long life".

Disponibile a richiesta olio alimentare.

Vedi Tabella 1 per oli e quantità consigliati.

Vedi Tabella 2 per i carichi radiali e assiali applicabili al riduttore.

Agip Telium VSF 320
Shell Omala S4 WE 320

B3
Standard
1.40 LT

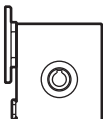

B8
On request
1.40 LT

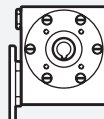

B6
On request
1.40 LT



V5
On request
1.40 LT



B7
On request
1.70 LT



V6
On request
1.40 LT



For more details on lubrication and plugs check our website.

Per maggiori dettagli su lubrificazione e tappi olio vedi il nostro sito web.

Radial and axial loads

Carichi radiali e assiali

Output shaft

Albero di uscita

n_2 [min ⁻¹]	F_A [N]	F_R [N]
200	500	2500
150	580	2900
100	600	3000
75	700	3500
50	800	4000
25	1000	5000
15	1160	5800

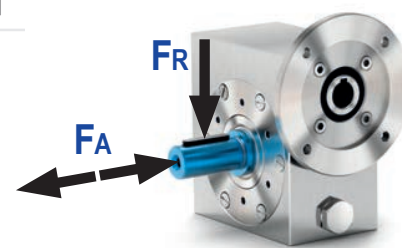

Input shaft

Albero in entrata

n_1 [min ⁻¹]	F_A [N]	F_R [N]
1400	160	809

* Strong axial loads in the DX direction are not allowed.

* Non sono consentiti forti carichi assiali con direzione DX

347 Nm

185

PI85UN...

Basic gearbox
Riduttore base

Gearbox weight 23.3 kg
peso riduttore

M. flanges	Kit code	øF	A
80-90B5	KI854042	200	118
100-112B14	KI854041	160	

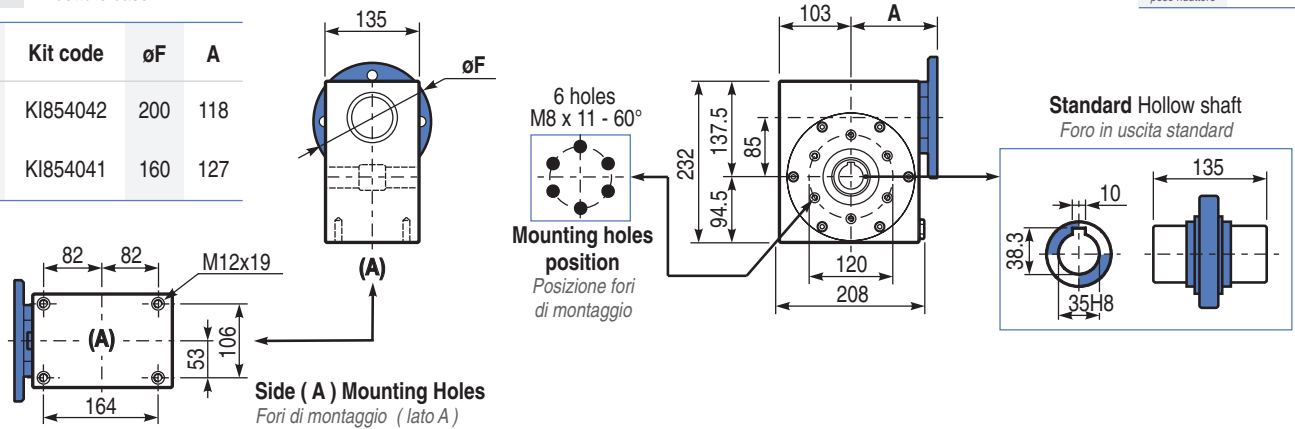

BI85UN...

Modular base
Base modulare

PI85FL...

Output flange
Flangia uscita

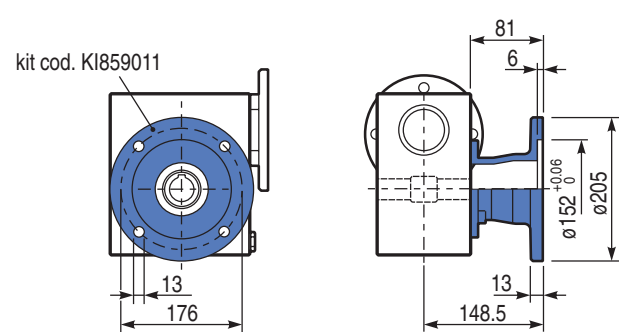
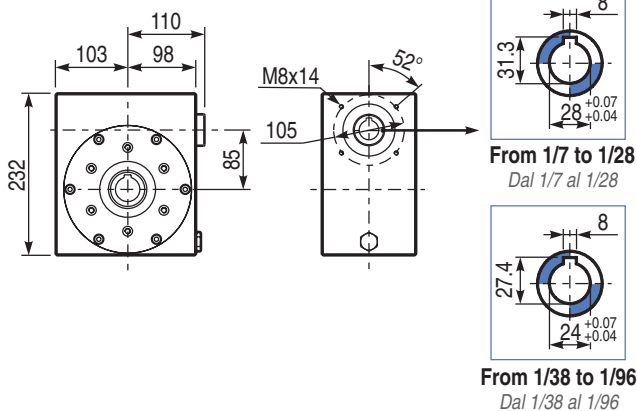

RI85UN...

Input shaft
Albero in entrata

PI85BR...

Reaction arm
Braccio di reazione

PI85.....S...

Single Shaft
Albero lento semplice

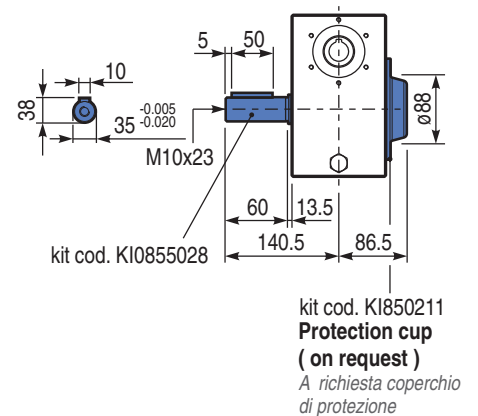
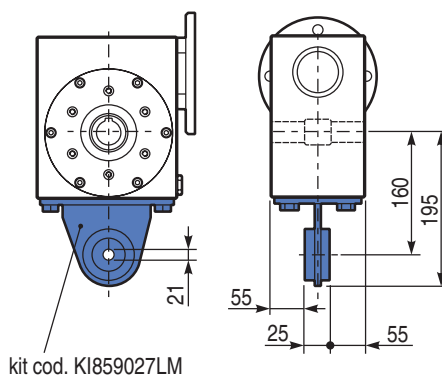
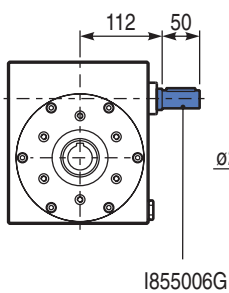



I11

651 Nm

Stainless steel worm gearboxes

Riduttori a vite senza fine completamente in acciaio inox

Input speed (n_1) = 1400 min⁻¹

Output speed n_2 [min ⁻¹]	Ratio i	Motor power P_{1M} [kW]	Output torque M_{2M} [Nm]	Service factor f.s	Nominal power P_{1R} [kW]	Nominal torque M_{2R} [Nm]	B5 motor flanges		B14 motor flanges	Dynamic efficiency RD	Tooth module  [mm]	Ratios code 
							-D	-E	-U			
200	7	4.0	168	2.9	11.5	483	B	B	100 - 112	88	5.5	01
140	10	4.0	235	2.2	9.0	525	B	B		86	5.4	02
88	16	4.0	358	1.5	6.0	536	B	B		82	5.3	03
70	20	4.0	447	1.2	4.9	546	B	B		82	4.5	04
61	23	3.0	377	1.4	4.1	515	B	B		80	3.9	05
47	30	3.0	467	1.4	4.2	651	B	B		76	5.6	06
37	38	3.0	583	1.1	3.3	641	B	B		75	4.7	07
31	45	2.2	493	1.2	2.7	599	B	B		73	4.0	08
26	53	2.2	557	1.1	2.5	620	B	B		70	3.5	09
22	64	1.5	452	1.2	1.8	536	B			69	2.9	10
16.7	84	1.1	410	1.2	1.3	494	B			65	2.2	11
14.1	99	1.1	446	1.1	1.2	483	B			60	1.9	12

* The nominal power should be reduced if the ambient temperature is $\geq 30^\circ\text{C}$, or when a cooler gearbox is required.

* Diminuire la potenza nominale in caso di temperatura ambiente $\geq 30^\circ\text{C}$ o se è richiesta una bassa temperatura di utilizzo del riduttore.

-  **Motor flanges available**
Flange motore disponibili
-  **B) Supplied with reduction bushing**
Fornito con bussola di riduzione
-  **B) Available on request without reduction bushing**
Disponibile a richiesta senza bussola di riduzione
-  **C) Motor flange holes position**
Posizione fori flangia motore

Lubrication

Lubrificazione

Unit I11 is supplied with synthetic oil to assure long life lubrication.

Food grade oil is available on request.

See Table 1 for lubrication and recommended quantity.

See Table 2 for possible radial and axial loads on the gearbox.

Il riduttore tipo I11 viene fornito con olio sintetico e lubrificazione tipo "long life".

Disponibile a richiesta olio alimentare.

Vedi Tabella 1 per oli e quantità consigliati.

Vedi Tabella 2 per i carichi radiali e assiali applicabili al riduttore.

Agip

Telium VSF 320

Shell

Omala S4 WE 320

B3

Standard
3.50 LT

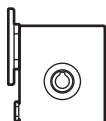

B8

On request
2.10 LT

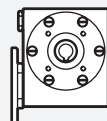

B6

On request
2.50 LT

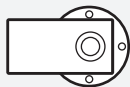

V5

On request
1.60 LT

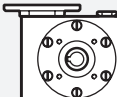

B7

On request
2.50 LT

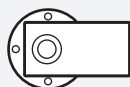

V6

On request
1.60 LT

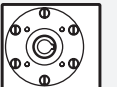

For more details on lubrication and plugs check our website.

Per maggiori dettagli su lubrificazione e tappi olio vedi il nostro sito web.

Radial and axial loads

Carichi radiali e assiali

Output shaft

Albero di uscita

n_2 [min ⁻¹]	F_A [N]	F_R [N]
200	600	2900
150	700	3300
100	750	3600
75	800	4000
50	920	4600
25	1200	6000
15	1400	7000

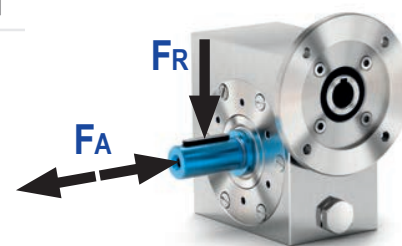

Input shaft

Albero in entrata

n_1 [min ⁻¹]	F_A [N]	F_R [N]
1400	228	1140

* Strong axial loads in the DX direction are not allowed.

* Non sono consentiti forti carichi assiali con direzione DX

651
Nm

111

PI11UN... **Basic gearbox**
Riduttore base

Gearbox weight
peso riduttore **38.5 kg**

M. flanges	Kit code	øF	A
80-90B5	KI854042	200	137.5
100-112B14	KI854041	160	146.5

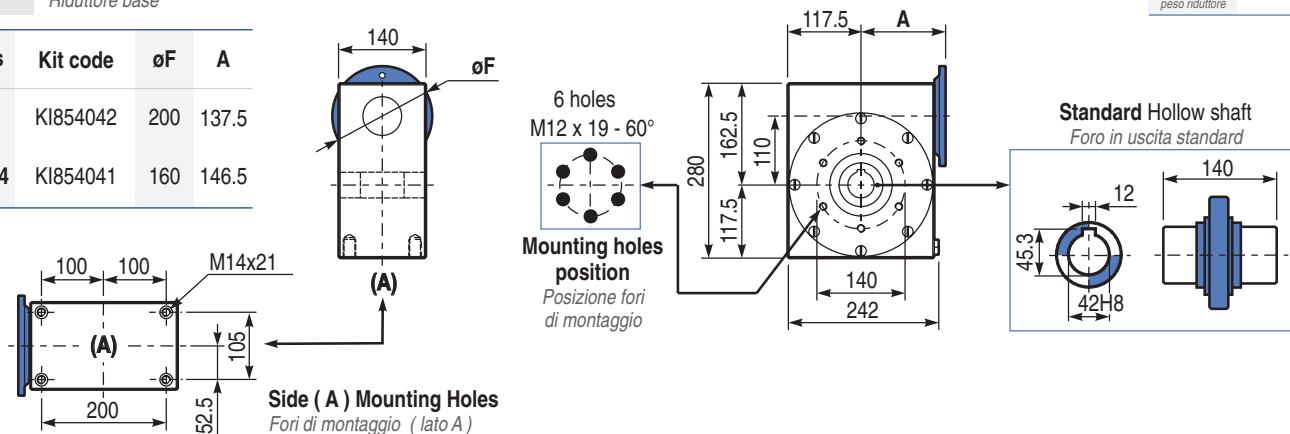

B111UN... **Modular base**
Base modulare

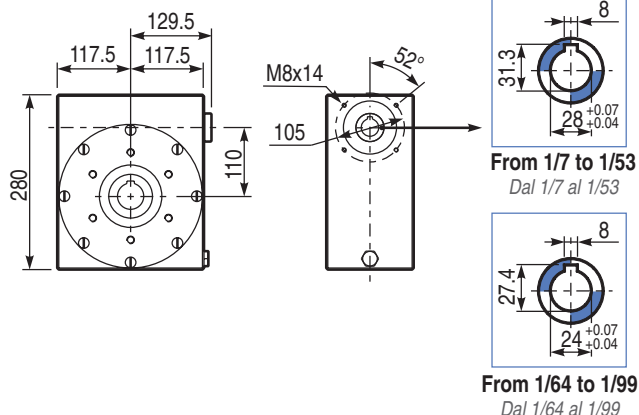

PI11BR... **Reaction arm**
Braccio di reazione

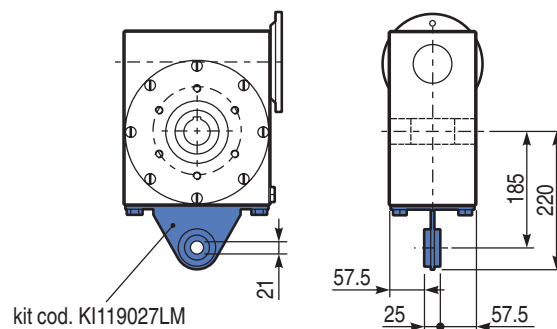

R111UN... **Input shaft**
Albero in entrata

